



TWIN-FLOIII®

INSTALLATION INSTRUCTIONS • TYPES W & F

RECESSED AND SURFACE MOUNT WALL KITS RECESSED "W" / SURFACE MOUNT "F" WALL KIT

**To be used in conjunction with Twin-FloIII • Type K
Kickspace Heater Installation Instructions
For use with K42/K84/K120 Kickspace Heaters**

ATTENTION: READ THESE INSTRUCTIONS CAREFULLY BEFORE ATTEMPTING TO INSTALL, OPERATE, OR SERVICE THE BEACON-MORRIS TWIN-FLO III HEATERS! RETAIN THESE INSTRUCTIONS FOR FUTURE REFERENCE.

INSPECT THE SHIPMENT IMMEDIATELY WHEN RECEIVED TO DETERMINE IF ANY DAMAGE HAS OCCURRED DURING SHIPMENT.

PRIOR TO INSTALL, CHECK FOR ANY VISIBLE DAMAGE.

GENERAL DESCRIPTION

The Twin-Flo III wall kits have been designed to accommodate a Beacon-Morris Twin-Flo III Model K42, K84, or K120 kickspace heater to deliver a comfortable stream of warmed air through the wall by a unit mounted in the wall, or on the surface of the wall. Kits consist of front grille panels, back panel, and necessary mounting hardware. The kickspace heater is sold separately.

The recessed (W kits) cabinet for the W42 will fit between 16" center studs. The W84/W120 will require a small amount of framing to suit the mounting.

Installation instructions should be read thoroughly IN CONJUNCTION WITH INSTALLATION INSTRUCTIONS AND WIRING DIAGRAM SUPPLIED WITH TWIN-FLO III HEATER UNITS, prior to starting installation.

**WARNING: DISCONNECT POWER BEFORE SERVICING UNIT,
POTENTIAL ELECTRICAL SHOCK HAZARD!**



260 NORTH ELM STREET, WESTFIELD, MASSACHUSETTS 01085
7555 TRANMERE DRIVE, MISSISSAUGA, ONTARIO L5S 1L4 CANADA
www.beacon-morris.com

INSTALLATION OF TWIN-FLO III WALL MODELS - TYPE "W" AND TYPE "F"

Figures D and F show exploded views of the wall models "W" & "F" Twin-Flo III's. Figure E shows the "W" type mounted in a wall with an air outlet at the top of the unit. Figure G shows the "F" type mounted. The louvers of the front panel will direct the air flow as shown. Use the following procedures for installation.

Type W Installation

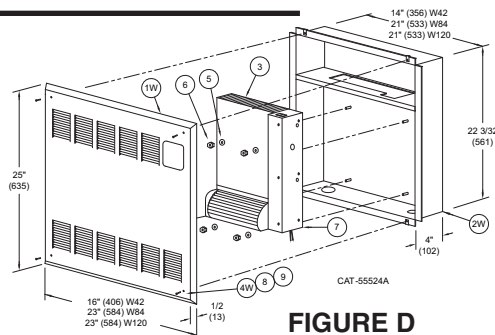

FIGURE D

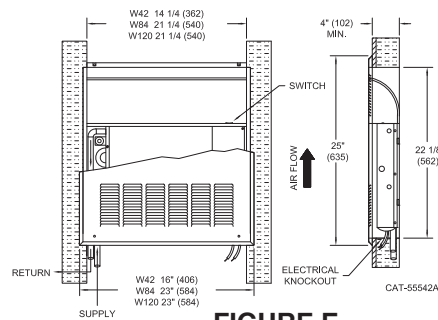

FIGURE E

	Description	Part No.	Model		
			42	84	120
Figure D Parts List					
1W	Front Panel Assembly	BMWRO2172-001	X		
		BMWRO2172-002		X	X
2W	Back Panel Assembly	BMWRO2169-001	X		
		BMWRO2169-002		X	X
3	Kickspace Unit (sold separately)	K42	X		
		K84		X	
		K120			X
4W	Front Panel Mounting Screws	J21-00282-003	X	X	X
5	Lockwashers	J24-00322-001	X	X	X
6	Flanged Nuts	J23-00324-001	X	X	X
7	Kickspace Electrical Box Cover	ref item #3	X	X	X
8/9	Snap Cap / Washers	J06-04481	X	X	X
Figure D	Complete Wall Assembly Type "W" (less heater)	W42	X		
		W84		X	
		W120			X

TYPE "W" :

- 1.) Frame an opening between wall studding as shown in Figure E. Model W42 will fit between studs that are on 16" centers. Model W84 and W120 will require a small amount of framing to suit the mounting. A 7/8" diameter hole is provided at the bottom of the cabinet interior to provide entrances for electrical connections, and a 7/8" diameter knockout is provided at the rear of the motor in the electrical control box. A 2-1/2" diameter hole is provided at the bottom of the cabinet interior to provide an entrance for piping connections. Cut horizontal framing to clear, as necessary.
- 2.) After removing the front panel mounting screws (Item 4W), remove the front louvered panel (Item 1W). Notice the direction of the louvers (see the air flow direction label on inside front label).
- 3.) Nail the recessed cabinet (Item 2W) to the framed opening at both sides.
- 4.) Mount the Kickspace Unit (Item 3) to the recessed back panel, remove the electrical control box cover from kickspace unit. Secure the kickspace unit in place using Items 5 & 6 as shown in Figure D. Do not over tighten.
- 5.) Remove the heating element from the kickspace unit (Item 3) following the procedure described in the

installation of Type "K". Hold this element and fittings temporarily in place in the recessed cabinet before soldering to check for clearance and length of tubing required.

- 6.) After piping connections have been made, replace the heating element in the bottom cover in the proper position. Place the neoprene side pad in position and replace the top cover using the 4 screws. Tighten enough to keep the element in place between the covers. **DO NOT OVER-TIGHTEN!**
- 7.) Electrical connections for the wall units are to be made as shown in Kickspace Type "K" Installation Manual page 3.
- 8.) Make final piping and electrical connections (see Kickspace Type "K" Installation Manual pages 3 & 4) to the system in the cabinet. Secure in place the kickspace electrical control box cover. Turn on the system, purge of air, check blower operation, and check for any possible leaks in the piping.
- 9.) Replace front panel (Item 1W), place washers (Items 8) in required positions, screw through holes and tighten.
- 10.) Place snap-cap® (Item 9) over washer at angle. Push snap-cap® (Item 9) DOWN firmly until it engages with a snap.

Type "F" Installation

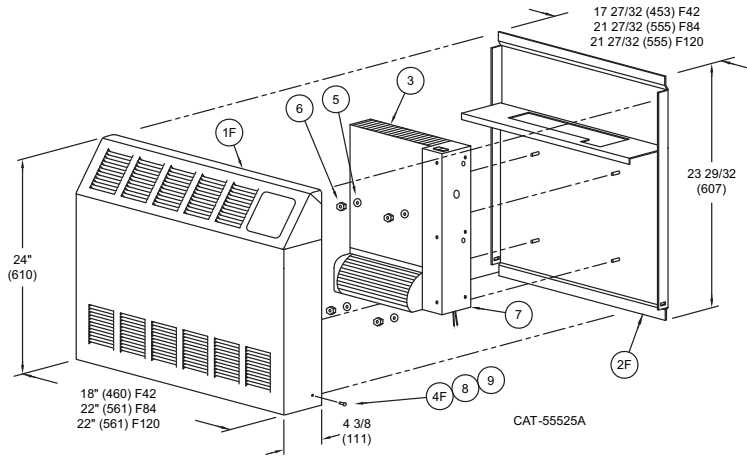

FIGURE F

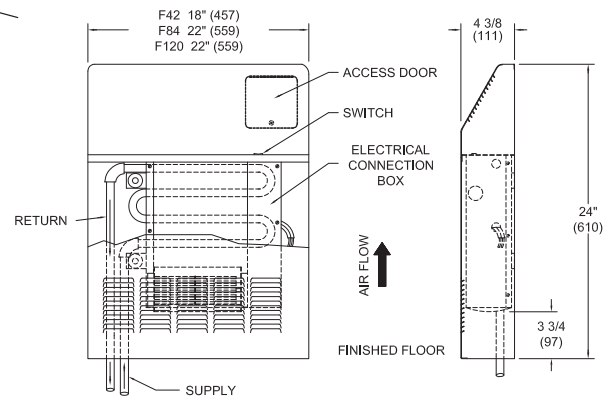

FIGURE G
(Model 42 Shown)

	Description	Part No.	Model		
			42	84	120
Figure F Parts List					
1F	Front Panel Assembly	BMFR02165-001	x		
		BMFR02165-002		x	x
2F	Back Panel Assembly	BMFR02161-001	x		
		BMFR02161-002		x	x
3	Kickspace Unit (sold separately)	K42	x		
		K84		x	
		K120			x
4F	Front Panel Mounting Screws	J21-00282-003	x	x	x
5	Lockwashers	J24-00322-001	x	x	x
6	Flanged Nuts	J23-00324-001	x	x	x
7	Kickspace Electrical Box Cover	ref item #3	x	x	x
8/9	Snap Cap / Washers	J06-04481	x	x	x
Figure F	Complete Surface Mount Wall Kit Type "F" (less heater)	F42	x		
		F84		x	
		F120			x

TYPE "F" :

- 1.) Locate the heater at or near floor level, and plan for water and electrical services feed through the bottom of the enclosure. If over rough flooring, be sure to allow clearance above the finish that will not interfere with removal of the front panel. The back panel (Item 2F) should be screwed or nailed securely to the wall.
- 2.) Remove the front panel (Item 1F) by removing the two screws at the bottom. Then pull the bottom away from the enclosure and lift the top from its hooked position. To replace the panel, press down firmly to engage it in the top channel and lock the two sides over the front edge of the enclosure at the clamps.
- 3.) Mount the Kickspace Unit (Item 3) to the back recessed panel, remove the electrical control box cover from Kickspace unit. Secure the Kickspace unit in place using items 5 & 6 as shown in Figure F. Do not over tighten.
- 4.) Soldering may be done to the kickspace unit (Item 3) with care within Type "F" enclosure, or the element may easily be removed, if so desired.
- 5.) After the piping connections are made, replace the heating element in the bottom cover in the proper position. Place the neoprene side pad in position and replace the top cover using the 4 screws. Tighten enough to keep the element in place between the covers. **DO NOT OVER-TIGHTEN!** Removal and replacement will be simpler if done in a horizontal position before the enclosure is secured to the wall.
- 6.) Electrical connections for the wall units are to be made as indicated in Type "K" Kickspace Installation Manual on page 3.
- 7.) Make final piping and electrical connections (see pages 5 & 6 in Type K Installation Manual) to the system in the cabinet. Turn on the system, purge of air, check blower operation, and check for any possible leaks in the piping.
- 8.) Replace front panel (Item 1F), place washers (Item 8) in required positions, screw through holes and tighten.
- 9.) Place snap-cap® (Item 9) over washer at angle. Push snap-cap® (Item 9) **DOWN** firmly until it engages with a snap.

LIMITED WARRANTY

Twin-Flo III Heaters

The "Manufacturer" warrants to the original owner at the original installation site that the Twin-Flo Kickspace Heaters (the "Product") will be free from defects in material or workmanship for five (5) years from the date of shipment from the factory. If upon examination by the Manufacturer the Product is shown to have a defect in material or workmanship during the warranty period, the Manufacturer will repair or replace, at its option, that part of the Product which is shown to be defective.

This limited warranty does not apply:

- (a) if the Product has been subjected to misuse or neglect, has been accidentally or intentionally damaged, has not been installed, maintained or operated in accordance with the furnished written instructions, or has been altered or modified in any way.
- (b) to any expenses, including labor or material, incurred during removal or reinstallation of the defective Product or parts thereof.
- (c) to any workmanship of any installer of the Product.

This limited warranty is conditional upon:

- (a) shipment, to the Manufacturer, of that part of the Product thought to be defective. Goods can only be returned with prior written approval from the Manufacturer. All returns must be freight prepaid.
- (b) determination, in the reasonable opinion of the Manufacturer, that there exists a defect in material or workmanship.

Repair or replacement of any part under this Limited Warranty shall not extend the duration of the warranty with respect to such repaired or replaced part beyond the stated warranty period.

THIS LIMITED WARRANTY IS IN LIEU OF ALL OTHER WARRANTIES, EITHER EXPRESS OR IMPLIED, AND ALL SUCH OTHER WARRANTIES, INCLUDING WITHOUT LIMITATION IMPLIED WARRANTIES OF MERCHANTABILITY OR FITNESS FOR A PARTICULAR PURPOSE, ARE HEREBY DISCLAIMED AND EXCLUDED FROM THIS LIMITED WARRANTY. IN NO EVENT SHALL THE MANUFACTURER BE LIABLE IN ANY WAY FOR ANY CONSEQUENTIAL, SPECIAL, OR INCIDENTAL DAMAGES OF ANY NATURE WHATSOEVER, OR FOR ANY AMOUNTS IN EXCESS OF THE SELLING PRICE OF THE PRODUCT OR ANY PARTS THEREOF FOUND TO BE DEFECTIVE. THIS LIMITED WARRANTY GIVES THE ORIGINAL OWNER OF THE PRODUCT SPECIFIC LEGAL RIGHTS. YOU MAY ALSO HAVE OTHER RIGHTS WHICH MAY VARY BY EACH JURISDICTION.



260 NORTH ELM STREET, WESTFIELD, MASSACHUSETTS 01085
7555 TRANMERE DRIVE, MISSISSAUGA, ONTARIO L5S 1L4 CANADA

